



SP45N

SELF PROPELLED WORK PLATFORM



44ft

Platform height

31ft 6in

Working Outreach

4ft 11in Narrow Chassis

Allows operation in confined areas

Bi-Energy Power Available

Optimizing utilization

500lbs SWL

Extra capacity for tools
and materials

Telescopic Upper Boom

Greater accuracy when
positioning platform

**Platform Rotation
& Jib-Boom**

Improving manoeuvrability on site



niftylift.com



nifty SP45N

The Nifty **SP45N** offers one of the best working envelopes in its class. Designed using the latest computer technology, it delivers unrivalled working outreach combined with pinpoint accuracy when positing the platform. A super narrow base as standard with the option of Bi-Energy power makes it ideal for a wide range of applications.

SAFETY FEATURES

- Automatic Failsafe Brakes
- Tilt Alarm
- Foam Filled or Solid Tires
- Manual Descent with Hand Pump
- Dual Controls (Platform & Base)
- Lock Valves on all Hydraulic Cylinders
- Dual Harness Points
- Meets OSHA and ANSI Regulations

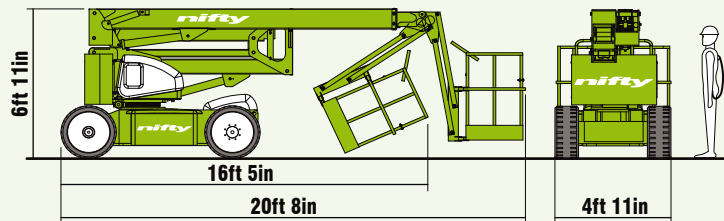
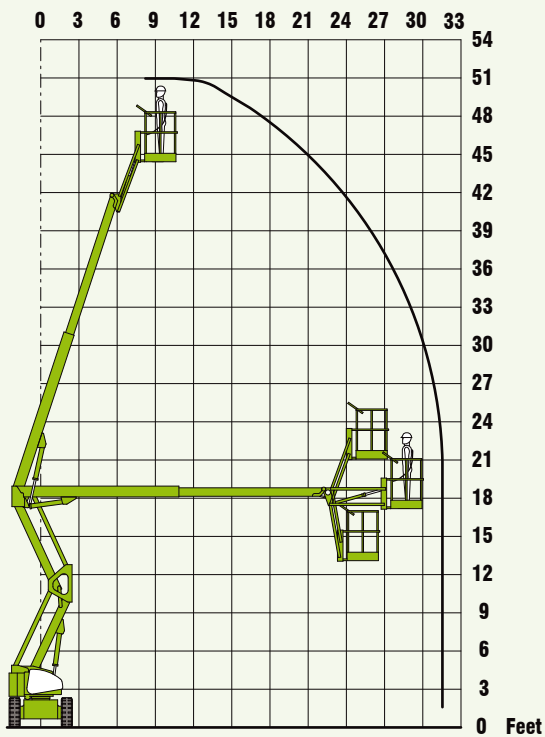
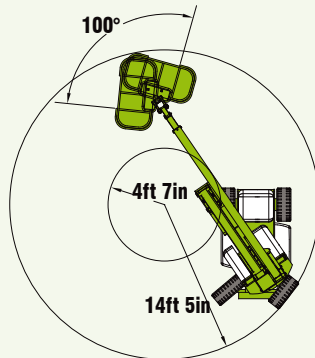

With more outreach than any other machine in its class and a base width of only 4ft 11in, the **SP45N** is one of the most effective and versatile self propelled platforms available.

SPECIFICATIONS

Working Height	50ft 6in
Platform Height	44ft
Working Outreach	31ft 6in
Slew	360°
Jib-Boom Arc	150°
Width	4ft 11in
Height	6ft 11in
Length - Stowed	16ft 5in
- Overall	20ft 8in
Minimum Weight	14,700lbs*
Turning Radius - Outside	14ft 5in
Platform Rotation	100°
Platform Capacity	500lbs
Platform Size	4ft 11in x 2ft 4in
Drive Speed	2.5 mph
Gradeability	25%
Control System	Fully proportional electric over hydraulic
Power System	Battery Only LPG Only Bi-Energy - Battery & Kubota 722 18Hp Diesel

* Weights may vary according to specification, please confirm before ordering.

Due to a policy of continuing development and improvement, Niftylift reserves the right to change any specification without notice. Please confirm exact specification before ordering.

Supplied by:

NIFTYLIFT INC

32 Concourse Way,
Greer, SC 29650 USA
Sales: 1-800-NIFTYLIFT (800-643-8954)
Office: 1-877-MYNIFTY (877-696-4389)
Fax: 1-864-968-8836
e.mail: info@niftylift.com
www.niftylift.com

NIFTYLIFT LTD

Fingle Drive, Stonebridge
Milton Keynes, MK13 0ER
England, United Kingdom
Tel.: +44 (0)1908 223456
Fax.: +44 (0)1908 312733
e.mail: info@niftylift.com
www.niftylift.com